

# Driver Meanwell XLG-150-H-A para Foco Modular LED Speed / Heatsing 150W

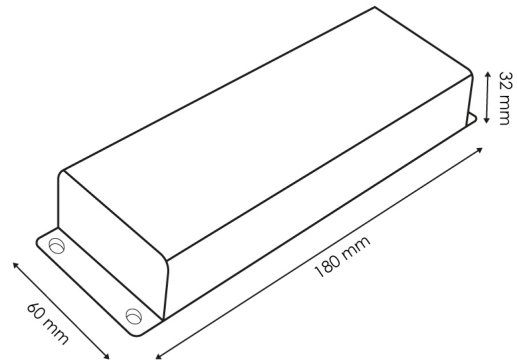

## Garantia / Warranty

Garantia do produto 5 Anos

## Tabela de Referências / Reference Table

LM2282 -

## Características / Technical Attributes

<b>Marca</b>	M LEDME
<b>Força maxima</b>	150
<b>Proteção</b>	IP67
<b>Alimentação</b>	100-305V AC
<b>Saída</b>	27-56V DC
<b>Amperagem</b>	2,8 A
<b>Dimensão</b>	180X60X35H mm
<b>Material</b>	Aluminio
<b>Fator de Potência</b>	0.95
<b>Garantía</b>	5

